

Made by

**NEWTEC BAG  
PALLETIZING**



## PALLETIZER SERIES 1000

The palletizer series 1000 is suitable for medium throughputs from 500 to 1,000 bags/hour. The modular design of this equipment guarantees you an optimal palletizing quality.

### Our advantages :

#### ■ Features

- layer palletizer for medium throughputs
- four side conforming plates with row pusher for compaction of the layer
- motorized lifting unit
- bag orientation with turning clamp or turning cross depending on the product

#### ■ Maintenance

- easy access to the inside of the machine for cleaning
- a touch screen allows access to the machine's menu

#### ■ Operational

- HMI allows manual operation and the modification of all parameters of the machine
- touch screen for machine menu and packing pattern program
- fully automatic palletizer without mechanical control

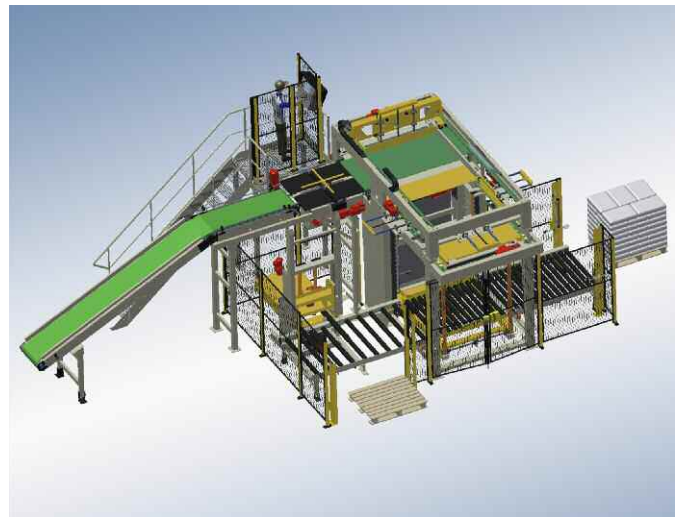

## TECHNICAL DATA

### PRODUCTS

Pet Food  
PVC powder  
Mortar  
Flour

### CAPACITY

500 to 1,000 bags/hr

### BAG TYPE

Paper valve bags or open bags  
PE valve bags or open bags  
PP valve bags ou open bags  
FFS bags

### BAG WEIGHT

5 to 50 kg

Made by

**NEWTEC BAG  
PALLETIZING**



## PALLETIZER SERIES 1000

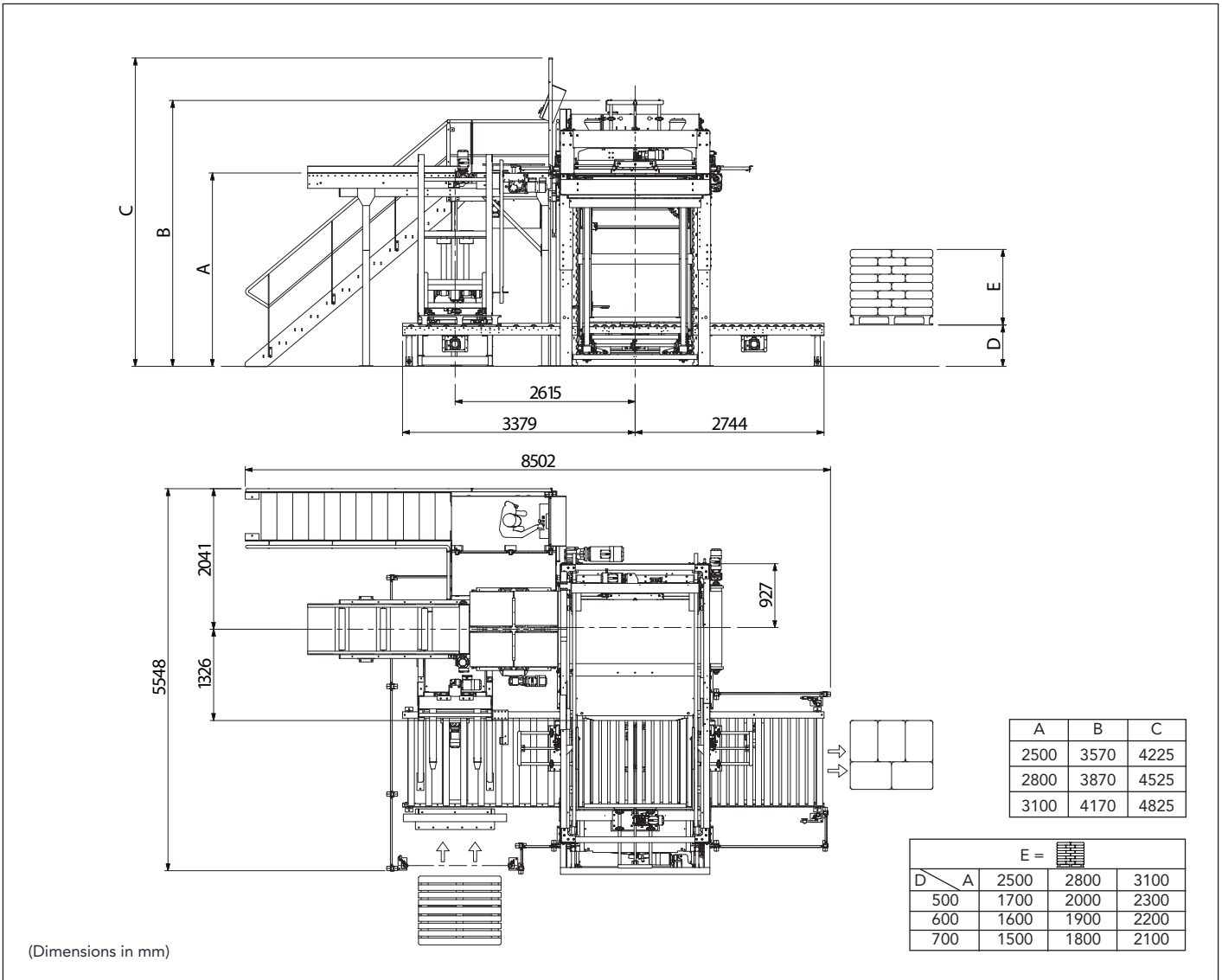

## TECHNICAL DATA

### ELECTRICITY AND PNEUMATIC

<b>OPERATING VOLTAGE</b>	380 V to 460 V/3 Ph	<b>INSULATION CLASS</b>	F
<b>FREQUENCY</b>	50 and 60 Hz	<b>PLC</b>	SIEMENS, ROCKWELL SCHNEIDER (in option)
<b>CONTROL VOLTAGE</b>	24 V DC	<b>AIR CONSUMPTION</b>	5 Nm <sup>3</sup> /h
<b>INSTALLED POWER</b>	18 kW	<b>INSTRUMENT AIR PRESSURE</b>	5 to 6 bars
<b>PROTECTION</b>	IP 55		