

Made by

PALLETIZER SERIES 1500

The palletizer series 1500 meets the requirements of medium throughputs from 1,000 to 1,500 bags/hour. The modular design of this equipment guarantees an optimal palletizing quality, taking into account the specifics of the different markets, such as the food industry, the chemical industry and the building materials industry.

Our advantages :

- Features
 - bag palletizer with layer deposit for medium working rate from 1,000 to 1,500 bags/hr
 - Turning cross or turning clamp for 90° or 180° bag turning
- Maintenance
 - easy maintenance
 - modem or VPN connection
 - low maintenance cost
- Operational
 - HMI allows manual operations and modification of all parameters of the machine
 - provided with a second row pusher



TECHNICAL DATA

PRODUCTS

Pet Food
Mortar
Plastic pellets

CAPACITY

1,000 to 1,500 bags/hr

BAG TYPE

Paper valve bags or open bags
PE valve bags or open bags
PP valve bags ou open bags
FFS bags

BAG WEIGHT

5 to 50 kg

Made by

**NEWTEC BAG
PALLETIZING**



PALLETIZER SERIES 1500

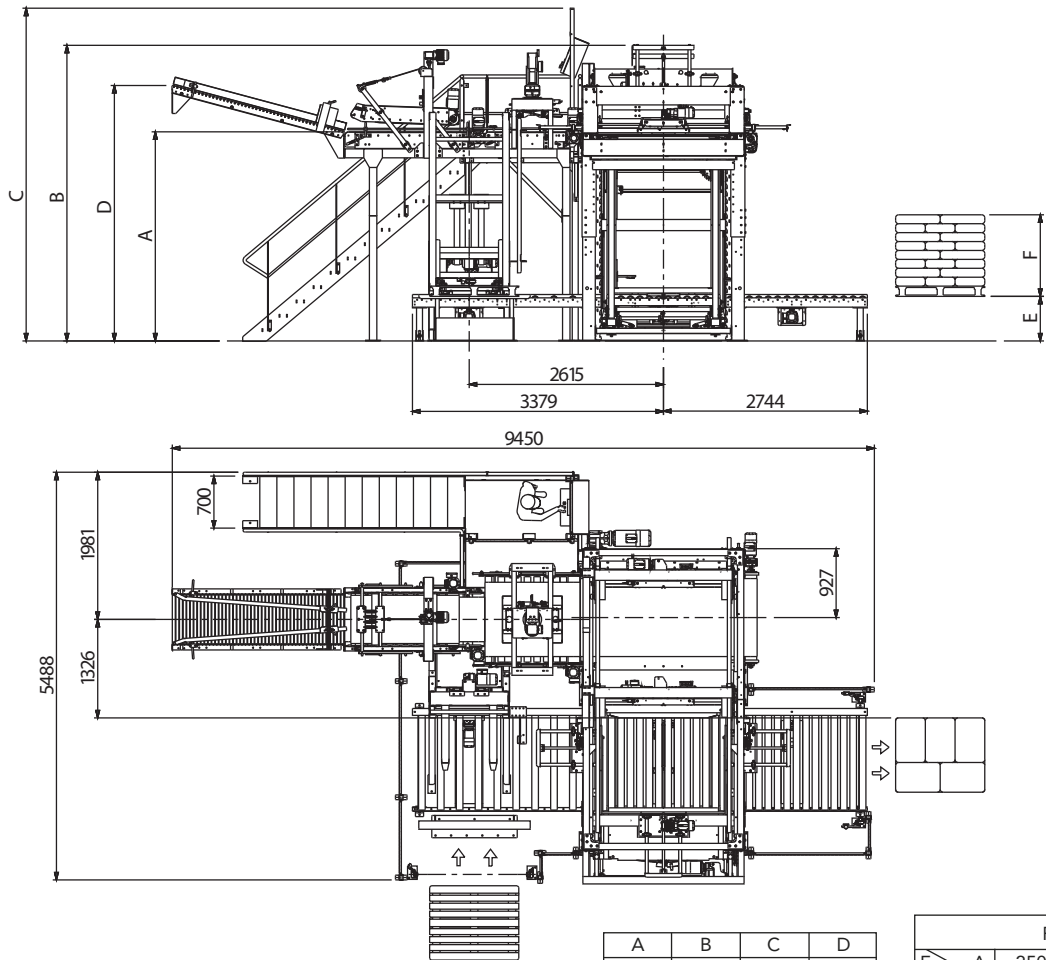

(Dimensions in mm)

A	B	C	D
2500	3570	4225	3150
2800	3870	4525	3450
3100	4170	4825	3750

		F = 		
E \ A	A	2500	2800	3100
500		1700	2000	2300
600		1600	1900	2200
700		1500	1800	2100

TECHNICAL DATA

ELECTRICITY AND PNEUMATIC

OPERATING VOLTAGE 380 V to 460 V/3 Ph
FREQUENCY 50 and 60 Hz
CONTROL VOLTAGE 24 V DC
INSTALLED POWER 35 kW
PROTECTION IP 55

INSULATION CLASS F
PLC SIEMENS and ROCKWELL
AIR CONSUMPTION 9 Nm³/h
INSTRUMENT AIR PRESSURE 5 to 6 bars